

Oil Lubricated Rotary Vane Vacuum Pumps & System



Suction capacity 10 to 780 m³/hr. (or more)
Continuous vacuum up to 0.1 mbar. (abs)

ABOUT US

With our professional and long years experience in the vacuum technology from Germany, we are proud to present our oil rotary vane vacuum pump "Dr.Vakuum".

The V series oil rotary vane vacuum pump is the latest premium products we have been developing for years. Its special design and high quality materials drives to be your smart solution for various applications & industries. V series are available for vacuum applications in capacity range from 10 m³/hr to 780 m³/hr (or more) with vacuum level up to 0.1 mbar (abs).



Air cooled and direct coupled monoblock design and the rugged construction and superior performance. Together with our long years experience distributor and excellent after-sales service support, we believed Dr.Vakuum is your true partner. Let's Dr.Vakuum generate vacuum and care for you.



TECHNICAL DATA



V0010



V0025C



V0040C



V0063



V0100



V0140



V0301B



V0630

Model	Nominal Speed		Ultimate Pressure	Motor Power		Motor Speed		Water Vapor Capacity	Sound Level	Inlet Connection	Oil Filling	Gross Weight	Dimensions	
	(m ³ /h)			(kW)		(rpm)							(L x W x H)(mm.)	
	50 Hz	60 Hz	50Hz	50 Hz	60 Hz	50 Hz	60 Hz	50Hz	50Hz	50Hz	50Hz	50 Hz	50Hz	
V0010	10	12	2	0.55	0.55	2800	3200	-	64	G1/2"	0.4	16	308 x 215 x 207	
V0016	16	19	2	0.55	0.55	2800	3200	-	64	G1/2"	0.4	16	308 x 215 x 207	
V0021C	20	24	1	0.75	0.75	2800	3200	0.5	65	G1/2"	0.75	21	447 x 236 x 173	
V0025C	25	30	1	0.75	0.75	2800	3200	0.5	65	G1/2"	0.75	22	431 x 245 x 218	
V0040C	40	48	0.5	1.1	1.3	1450	1750	0.7	64	G1 1/4"	1.5	43	646 x 287 x 266	
V0063	63	75	0.5	1.5	1.8	1450	1700	1	65	G1 1/4"	2	54	620 x 405 x 290	
V0100	100	120	0.5	2.2	3.0	1450	1700	1.5	66	G1 1/4"	2	69	710 x 405 x 290	
V0140	132	-	0.5	3	-	1450	-	2	67	G1 1/2"	3	90	752 x 445 x 285	
V0160B	160	192	0.5	4.0	4.8	1450	1700	2.5	72	G2"	8	142	760 x 496 x 410	
V0200B	200	240	0.5	4.0	5.5	1450	1700	4.0	73	G2"	8	142	795 x 496 x 410	
V0251B	250	300	0.5	5.5	6.3	1450	1700	3.5	72	G2"	10	192	976 x 605 x 411	
V0301B	300	360	0.5	7.5	7.5	1450	1700	4.5	73	G2"	10	198	1020 x 605 x 411	
V0630	630	780	0.1	17.5	18.5	1450	1700	17	75	DN100	24	670	1600 x 900 x 754	

PERFORMANCE CURVE

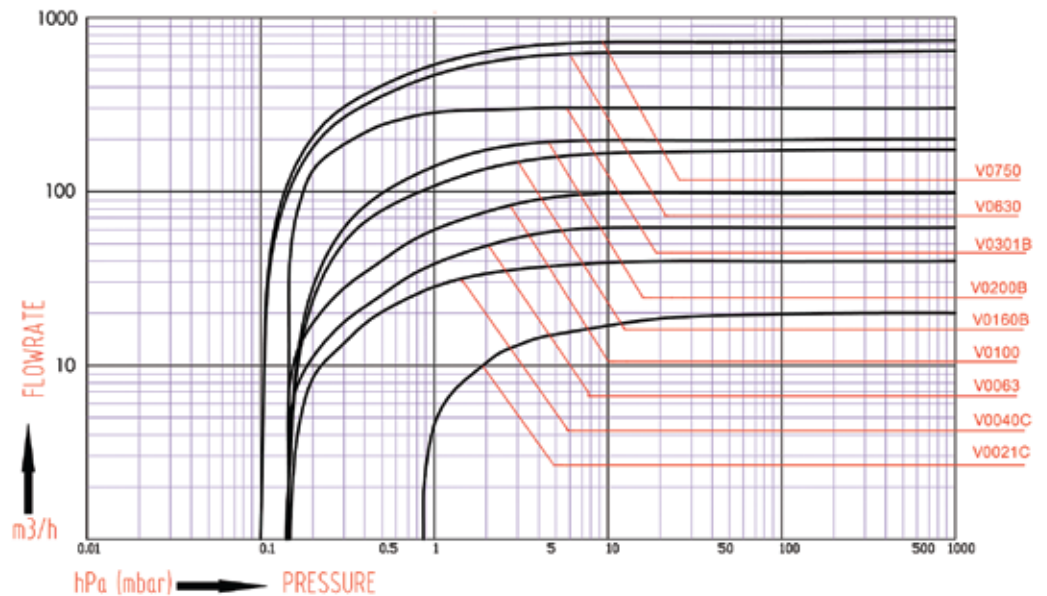

DIMENSION

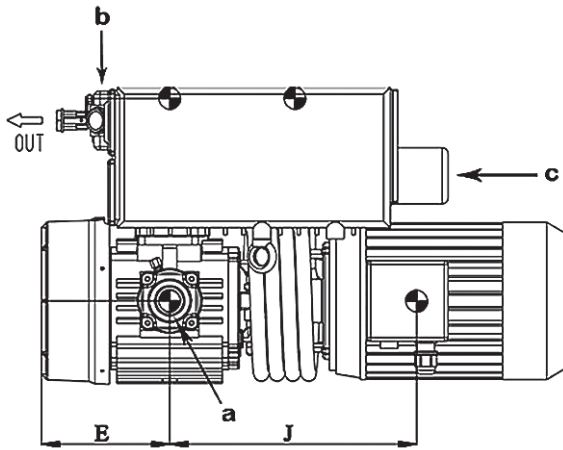
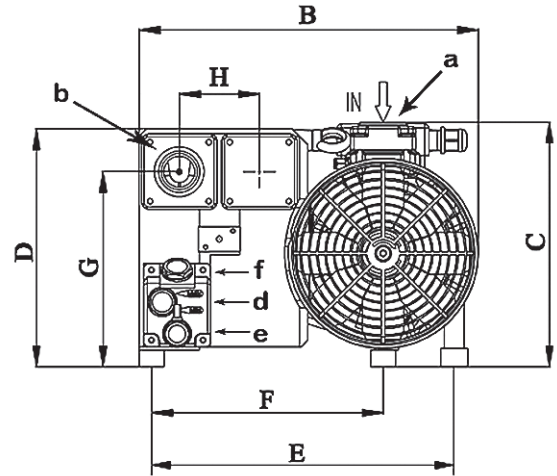
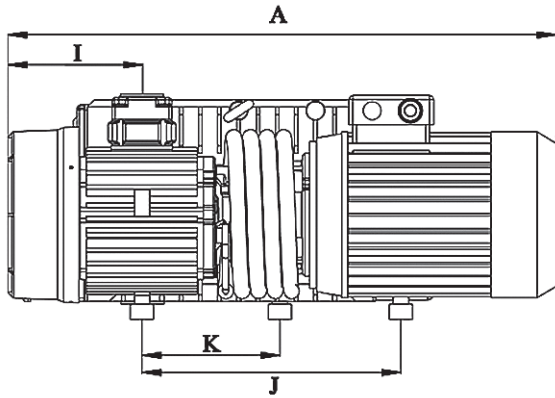

- a** Inlet port
- b** Outlet port
- c** Oil filter
- d** Oil sight glass
- e** Oil drain plug
- f** Oil fill plug

Dimension (mm)	A	B	C	D	E	F	G	H	I	J	K	Weight (Kg)	Noise (dB)	Inlet (inch)
V0010	308	212.5	139	203	112	-	163	-	54	150	-	16	64	G1/2"
V0016	308	212.5	139	203	112	-	163	-	54	150	-	16	64	G1/2"
V0021C	447	236	173	200	131	140	150	-	62	230	-	21	65	G1/2"
V0025C	426	259	200	202	-	150	151	-	150	235	-	22	65	G1/2"
V0040C	646	287	266	270	240	173	220	-	154	336	-	43	64	G1 1/4"
V0063	620	405	290	280	-	277	230	95	140	310	-	54	65	G1 1/4"
V0100	710	405	290	293	-	277	235	95	175	350	-	69	66	G1 1/4"
V0140	752	445	285	291	-	300	235	92	142	243	243	90	67	G1 1/2"
V0160B	760	496	410	-	-	305	320	-	189	366	243	142	72	G2"
V0200B	795	496	410	410	-	305	320	-	189	366	243	142	73	G2"
V0251B	976	605	411	-	-	370	321	-	267	390	303	192	72	G2"
V0301B	1026	605	410	410	-	370	321	-	267	390	303	198	73	G2"

PRODUCTS



V0010

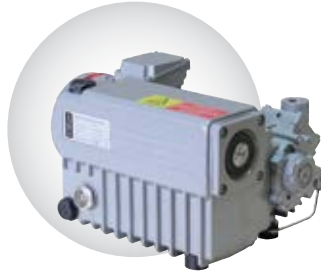

V0021C



V0063

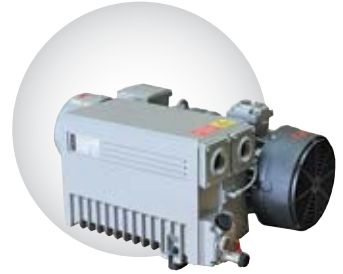

V0100

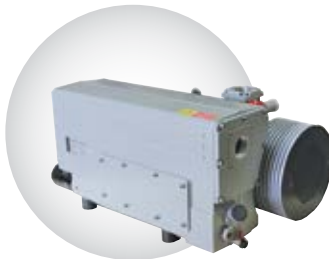

V0301B



V0630

- Compact design
- High Performance
- Quiet operation
- Oil mist elimination on discharge, exhaust air is 99.9% oil free
- High water vapor tolerance
- Simple installation
- Built in gas ballast valve
- Air-cooled

APPLICATION FOR INDUSTRIES



Food & Packaging



Plastic



Automotive



Electronic



Hospital & Medical



Pharmaceutical

- Vacuum central System
- Printing & Paper
- Laboratory
- Transformer Drying
- Vacuum Lifting
- Vacuum degassing
- Pneumatic conveyor
- Pu & Polyresin
- Jewelry
- Chemical & Processing
- Etc.

VACUUM SOLUTION & SYSTEM



“Dr.Vakuu” Oil Lubricated Rotary Vane Vacuum Pumps and Vacuum Systems

A completely new range of rotary vane vacuum pumps and high performance with long trouble-free life are suitable for factories, laboratories and manufacturers as well as OEMs.

Building on this unique experience, Dr.Vakuu has now testing and field trials produced the perfect Oil Lubrication rotary vane pump and accessories for all industrial applications.

Distributed by

